



R155 DUAL POWER SCREENER

One of the most versatile in the R Series screeners, the R155 High Energy Screener is available in several configurations including Dual Power, and is a tough, robust screening tool designed to cope with the heaviest of applications. The R155 Dual Power brings versatility to any site, while reducing operational costs and CO₂ emissions. With the ability to handle some of the worst, untreated construction and demolition waste, the R155 can minimize material pre-handling and provide clean end products.

FEATURES

- ✓ 4.880m x 1.525m (16'x5') heavy duty high energy 2 bearing screenbox
- ✓ 97 kW (127 Hp) Diesel Engine 37 kW (50 Hp) Electric Motor
- ✓ Direct feed Hardox® lined hopper
- ✓ Travel out fixed walkways
- ✓ Integrated hydraulic folding stockpiling conveyors
- ✓ Fast on site setup time – 10 minutes
- ✓ Screen raises at lower end for easy bottom deck access
- ✓ Service standing room inside Powerpack
- ✓ Track mobile



The R155 has proven to be extremely effective across a wide range of applications. With a screening area of 155 ft² across the High Energy Screenbox – the largest in its class – the R155 has impressed operators working with difficult materials.

The R155 dual power screener incorporates both diesel and electric power options, providing flexibility in selecting the most appropriate power source for a given situation.

The ability to switch between diesel and electric power reduces fuel consumption, lowers operating costs, and minimizes environmental impact.

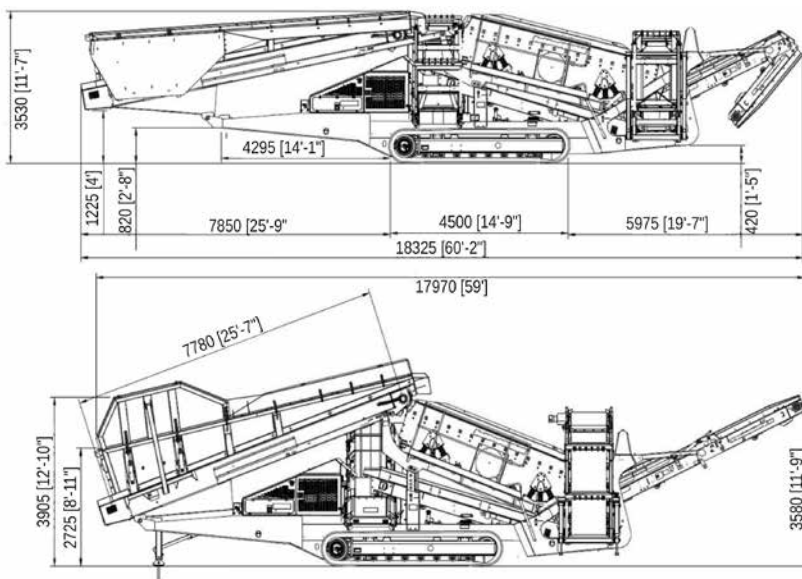

TECH SPECS

Engine

Diesel Electric or Dual Power Hybrid 130 Hp (97 kW)

Stockpile Height

Tail Conveyor 3.75m (12' 3")
Fines Conveyor 3.96m (13")
Mid Conveyor 3.60m (11' 10")

Screenbox

Top Deck 4.880m x 1.525m (16' x 5')
Bottom Deck 4.575m x 1.525m (15' x 5')

TRANSPORT

Transport Height 3.40m (11' 2")

Transport Length 15.3m (50' 2")

Transport Width 2.90m (9' 6")

Weight - Belt Feeder 32,700 Kgs (72,091 lbs)

Weight - Apron Feeder 35,420 Kgs (78,090 lbs)

OPTIONS

Heavy duty top deck finger screen | Bottom deck finger screen | Top deck punch plate | Bottom deck punch plate | Top deck Bofor screen | Radio remote control for tracks | Plate apron feeder | 365 SiteConnex Telematics