



PORTABLE FEED HOPPER

Designed to Receive Large Quantities of Bulk Materials



BENEFITS

- » Reliable feed to crushing, screening and washing plants.
- » Adjustable grizzly bars easily remove oversized material.
- » Easy setup and take down to quickly move from site to site.
- » Tried-and-true Superior components including idlers, pulleys and belt cleaners.
- » Available in three hopper configurations
 - » Wheel Mounted
 - » Skid Mounted

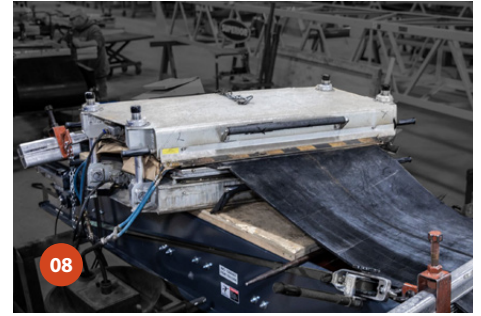
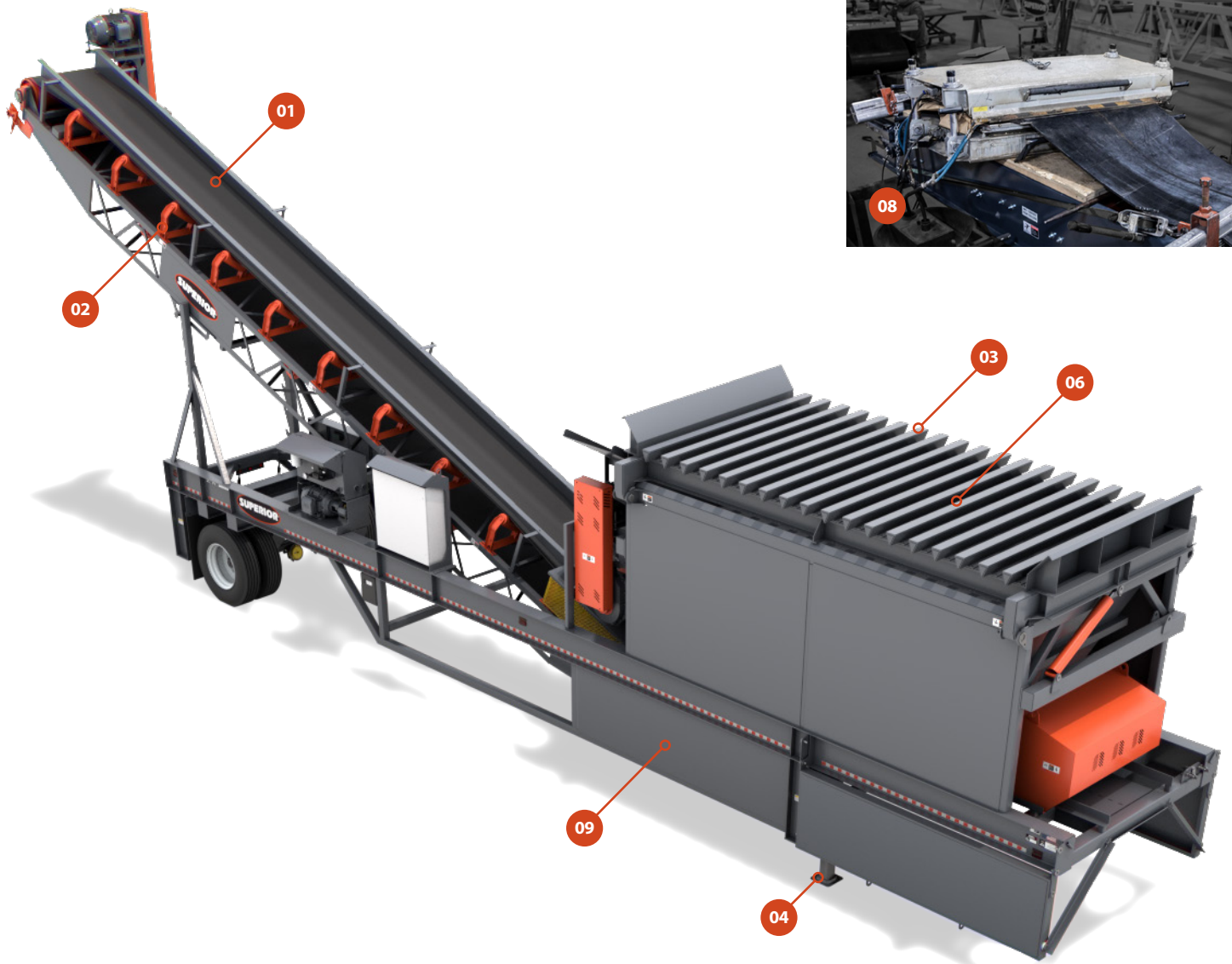

01/ 3-PLY CONVEYOR BELT

An internal layer of strong woven fabric is surrounded by top and bottom covers that protect the inner layer.

02/ SUPERIOR IDLERS

Depending on your load, choose from CEMA C or D rated idlers, which are manufactured with industry-leading bearing defense.

03/ ADJUSTABLE GRIZZLY BARS

Available in multiple styles so you can produce many products with a single grizzly.

04/ CRANK DOWN LANDING LEGS

Quickly and easily transition the hopper from operation to travel modes. Upgrade to hydraulic for an automatic shift.

05/ ADJUSTABLE FLOW GATE

Choose your setting to control the amount of material that runs from the hopper to the discharge conveyor. (not shown)

06/ 935 TPH (850 MTPH) CAPACITY

Robust design standards preserve the framework of machinery in the highest capacity applications. Upgrade to 1,320 TPH (1,200 MTPH).

07/ CHEVRON® PULLEY

Patented v-shaped tail pulley ejects fugitive material for longer-lasting pulleys and belts. (not shown)

08/ VULCANIZED BELT SPLICE

Smooth splice with minimal risk of snagging, tearing or other harmful wear to the belt.

09/ FRAME SKIRTING

Protects components at the underside of hopper from damaging fugitive material.

OPTIONS



HYDRAULIC GRIZZLY DUMP



GRIZZLY BAR STYLES

- » 42" (1,066mm) belt width (1,200 TPH upgrade)
- » Hydraulic Grizzly Dump
- » Remote for Grizzly
- » Canoe Liners Along Belt Feeder
- » Control Panel
- » Wireless Remote Control
- » Live Shaft Rollers
- » Hopper/Frame Skirts
- » Hydraulic Lift Jacks
- » CEMA Rated Idlers



CANOE LINERS



CONTROL PANEL

GRIZZLY BARS

- » Triangle Grizzly Bars standard on:
 - » PBF10
 - » PBF15
 - » PFH10
 - » PFH15
- » Round Grizzly Bars standard on:
 - » PFH15HD
- » Round Grizzly Bars upgrade on:
 - » PBF10
 - » PBF15
 - » PFH10
 - » PFH15
- » Heavy-T Grizzly Bars upgrade on:
 - » PFH15HD

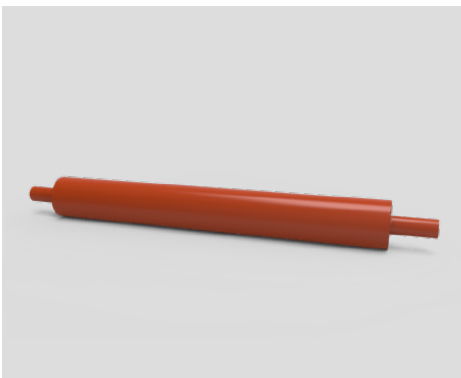

LIVE SHAFT ROLLER

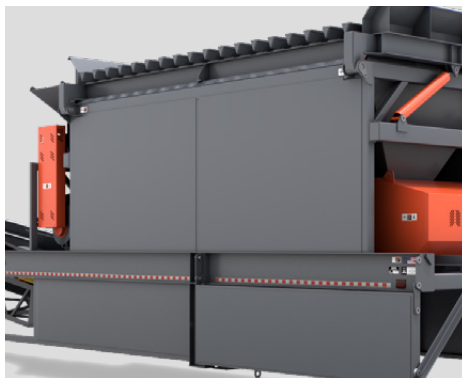

HOPPER/FRAME SKIRTS



HYDRAULIC LIFT JACKS



CEMA RATED IDLERS

SPECIFICATIONS

PORTABLE BELT FEEDER

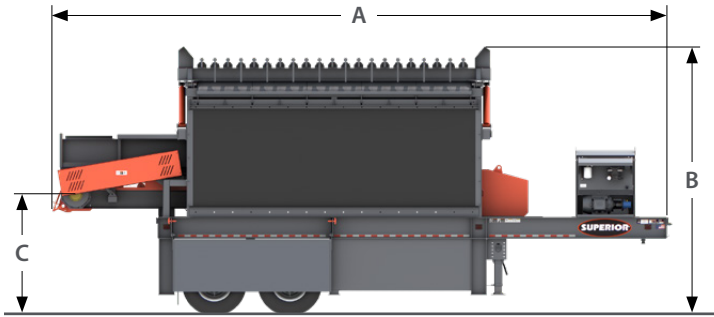

	PBF10		PBF15	
	Imperial	Metric	Imperial	Metric
(A) Overall Length	33'-6"	10.2m	36'-0"	10.9m
(B) Overall Height	14'-0"	4.2m	14'-0"	4.2m
(C) Discharge Conveyor Full Raise	6'-6"	1.9m	6'-6"	1.9m
Overall Width	9'-6"	2.8m	10'-6"	3.2m
Belt Feeder Conveyor Length	22'-0"	6.7m	24'-0"	7.3m
Hopper Size	8' x 16'	2.4m x 4.8m	9' x 18'	2.7m x 5.4m
Hopper Capacity (yd ³ struck)	10	7.6m ³	15	11.4m ³
Hopper Capacity (short tons/100PCF)	13.5	12.25 tonnes	20.25	18.37 tonnes
Feeder Belt Width	36"	915mm	36"	915mm
Discharge Rate (TPH)	250-850	225-770 MTPH	250-850	225-770 MTPH

PORTABLE FEED HOPPER WITH 40' DISCHARGE CONVEYOR

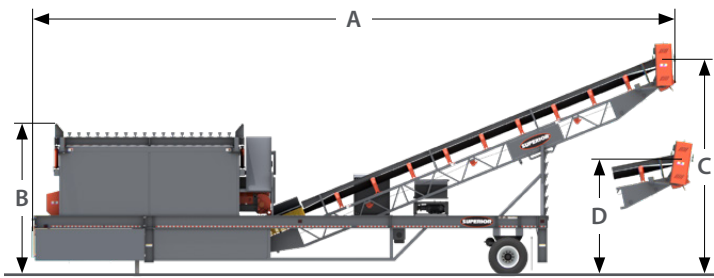

	PFH10		PFH15	
	Imperial	Metric	Imperial	Metric
(A) Overall Length	60'-0"	18.2m	62'-0"	18.8m
(B) Overall Height	13'-6"	4.1m	13'-6"	4.1m
(C) Discharge Conveyor Full Raise	17'-10"	5.4m	17'-10"	5.4m
(D) Discharge Conveyor Lowered	9'-7"	2.9m	9'-7"	2.9m
Overall Width	9'-0"	2.7m	10'-6"	3.2m
Belt Feeder Conveyor Length	18'-0"	5.4m	20'-0"	6.0m
Discharge Conveyor Length	40'-0"	12.1m	40'-0"	12.1m
Hopper Size	8' x 16'	2.4m x 4.8m	9' x 18'	2.7m x 5.4m
Hopper Capacity (yd ³ struck)	10	7.6m ³	15	11.4m ³
Hopper Capacity (short tons/100PCF)	13.5	12.25 tonnes	20.25	18.37 tonnes
Feeder Belt Width	36"	915mm	36"	915mm
Discharge Belt Width	36"	915mm	36"	915mm
Discharge Rate (TPH)	250-850	225-770 MTPH	250-850	225-770 MTPH

HEAVY DUTY PORTABLE FEED HOPPER WITH 50' DISCHARGE CONVEYOR

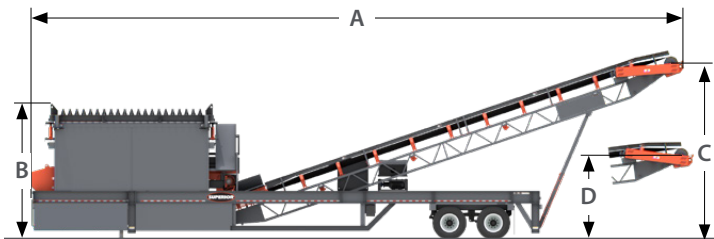

	PFH15HD	
	Imperial	Metric
(A) Overall Length	67'-0"	20.4
(B) Overall Height	14'-2"	4.3
(C) Discharge Conveyor Full Raise	17'-10"	5.4
(D) Discharge Conveyor Lowered	9'-4"	2.8
Overall Width	9'-3"	2.8
Belt Feeder Conveyor Length	18'-0"	5.4
Discharge Conveyor Length	50'-0"	15.2
Hopper Size	8' x 16'	2.4m x 4.8m
Hopper Capacity (yd ³ struck)	15	11.4m ³
Hopper Capacity (short tons/100PCF)	20.25	18.37 tonnes
Feeder Belt Width	42"	1,066mm
Discharge Belt Width	42"	1,066mm
Discharge Rate (TPH)	1,000	907 MTPH